

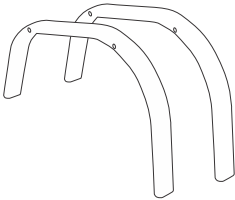



 <p>concha (X2)</p>	<p>01 a)</p>  <p>barra rosca união (x3)</p>
 <p>estrutura fixa (pés)</p>	<p>b)</p>  <p>parafuso ALL CH M8x80 (x6)</p> <p>c)</p>  <p>porca sextavada M8 ZNB (x18)</p> <p>d)</p>  <p>parafuso ALL 5/16 x 1/2 (x2)</p>
 <p>pé intermediário</p>	<p>03 e)</p>  <p>parafuso ALL CH M8x35 (x2)</p>
 <p>braço</p>	<p>04</p>

Passo 01:

- a) Virar as conchas (item 01) de modo a visualizar a parte inferior do assento;
- b) Localizar os furos nas laterais das conchas, (antes e depois de tapeçar);
- c) Fixar o pé intermediário (item 03) com 3 barras rosca união (item a) e 12 porcas sextavadas (item c). Obs.: Deve-se utilizar 4 porcas para cada barra rosca.

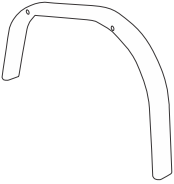

- Passo 02:** Após fixar o pé intermediário no passo 01, fixar os pés laterais (item 2). Verificar procedimento conforme ilustrado e utilizar 3 parafusos (item b) e 3 porcas (item c) para cada lateral.

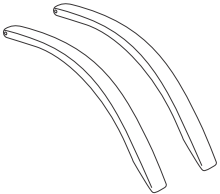
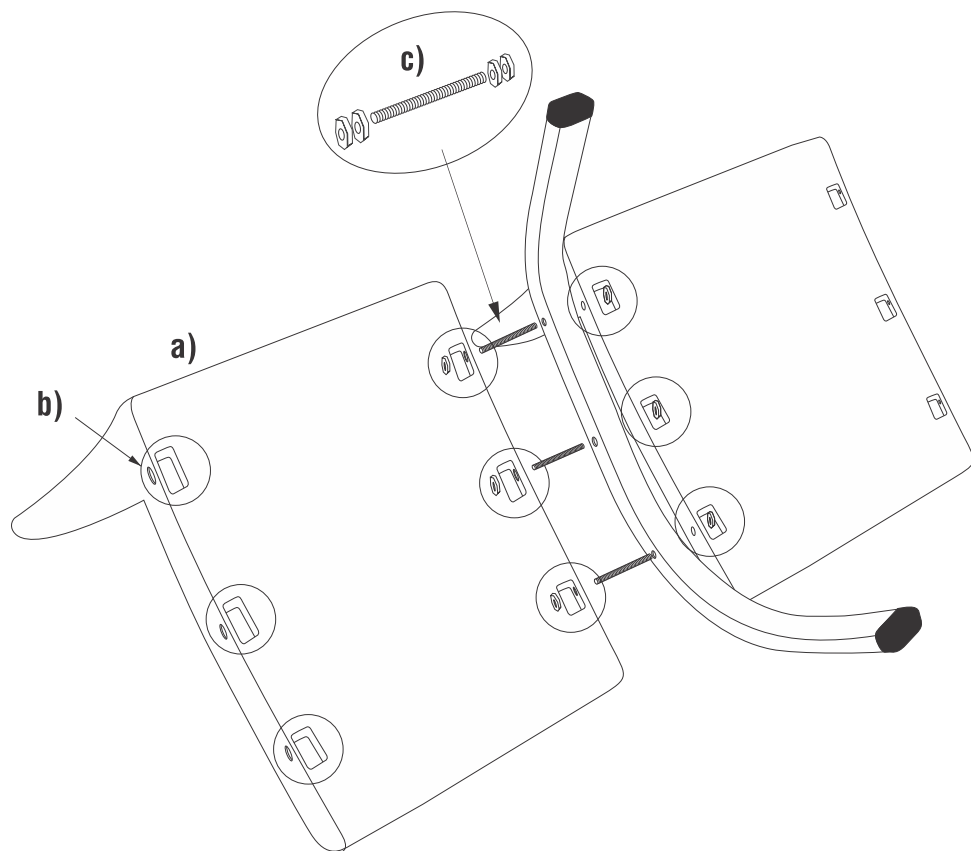
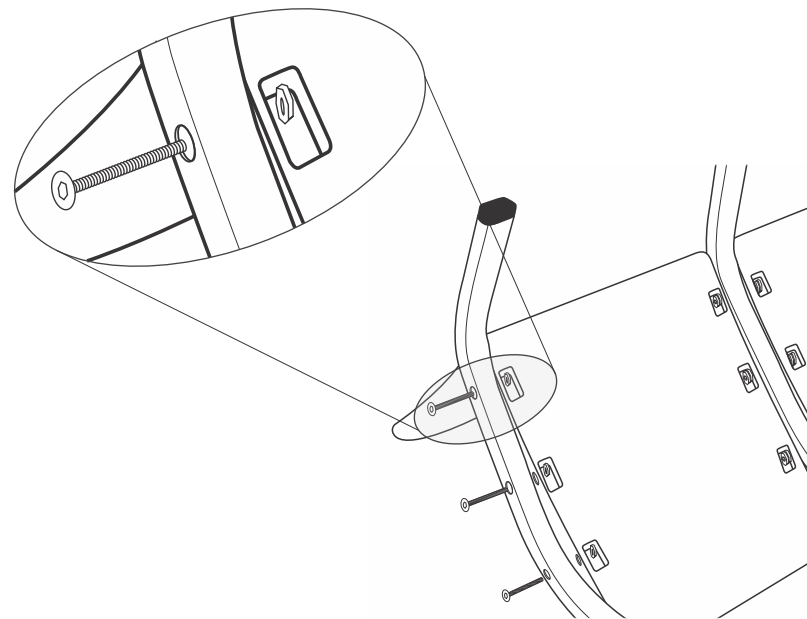

- Passo 03:** Após fixar os pés, virar a poltrona na posição de sentar e fixar os braços (item 04).

Cada braço deverá ser fixado no encosto e na estrutura fixa: Para fixar o braço no encosto, utilizar 1 parafuso (item d) e, para fixar na estrutura fixa utilizar com 1 parafuso (item e).

